

SERVICE

Modell 640 LC4-E '98

Kabelstrangnummer  
vorne 584 11 175 100  
hinten 584 11 176 100

Land  
DIV LANDEK

Datum, Name  
16 04 98 KE

Kabelstrangbez  
vo  
hi

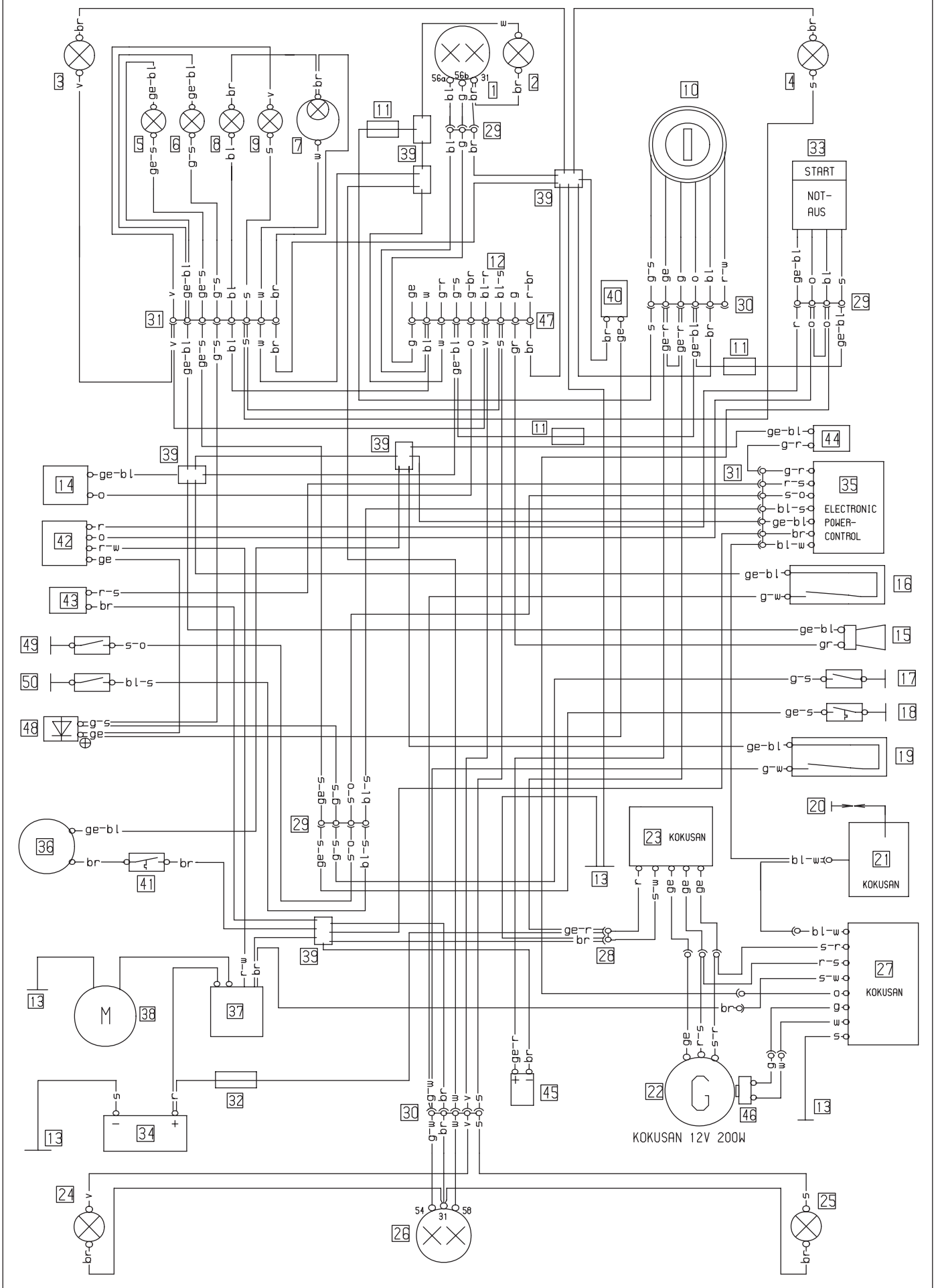

Deutsch	Englisch	Italienisch	Französisch
1 Scheinwerfer	1 headlight	1 faro	1 phare
2 Standlicht	2 parking light	2 luce di posizione	2 feu de position
3 Blinker li vo	3 blinker left front	3 lampegg ant sn	3 clignoteur av gauche
4 Blinker re vo	4 blinker right front	4 lampegg ant dx	4 clignoteur av droit
5 Temperaturkontrolle	5 temperature control	5 controllo temperatura	5 témoin de température
6 Leerlaufanzeige	6 neutral	6 indicat marcia folle	6 ind de point mort
7 Tachobeleuchtung	7 tachometer light	7 luce di tachimetro	7 éclair comp vitesse
8 Fernlichtkontrolle	8 high beam control	8 spia abbagliante	8 témoin de feu route
9 Blinkerkontrolle	9 blink control	9 spia lampeggiatori	9 témoin de clignoteur
10 Zündschloß	10 ignition switch	10 int accensione	10 contact d'allum
11 Sicherung 10A	11 fuse 10A	11 fusibile 10A	11 fusible 10A
12 zum Kombischalter	12 to combinat switch	12 multicomando	12 vers commutateur
13 Masseanschluß	13 ground connection	13 collegam a massa	13 masse
14 Blinkgeber	14 blink signal system	14 trasmett di lampeg	14 centrale clignot
15 Horn	15 horn	15 clacson	15 klaxon
16 Bremslichtsch vo	16 stoplight switch f	16 int luce arresto ant	16 cont av de stop
17 Leerlaufschalter (N)	17 idle switch (N)	17 interr luce folle (N)	17 contact pt mort (N)
18 ThermoSchalter	18 temperature switch	18 int temperatura	18 contact de temperature
19 Bremslichtsch hi	19 stoplight switch r	19 int luce arresto post	19 contact arr de stop
20 Zündkerze	20 spark plug	20 candela	20 bougie
21 Zündspule	21 ignition coil	21 bobina d'accens	21 bobine d'allumage
22 Generator	22 generator	22 dinamo	22 generateur
23 Regelgleichrichter	23 regulator-rectifier	23 regolatore di tens	23 regulat redresseur
24 Blinker li hi	24 blinker left rear	24 lampegg post sn	24 clign arr gauche
25 Blinker re hi	25 blinker right rear	25 lampegg post dx	25 clign arr droit
26 Brems-Schlußlicht	26 rear-stoplight	26 fanal post di freno	26 feu arr et de stop
27 CDI-Einheit	27 CDI-unit	27 CDI-seatola	27 boitier CDI
28 2-pol Stecker	28 multip cont plug (2)	28 connettore a 2 poli	28 connect multiple (2)
29 4-pol Stecker	29 multip cont plug (4)	29 connettore a 4 poli	29 connect multiple (4)
30 6-pol Stecker	30 multip cont plug (6)	30 connettore a 6 poli	30 connect multiple (6)
31 9-pol Stecker	31 multip cont plug (9)	31 connettore a 9 poli	31 connect multiple (9)
32 Hauptsicherung 20A	32 mainfuse 20A	32 fusibile principale 20A	32 fusible principal 20A
33 Starttast Notaussch	33 run-off/start switch	33 disinseritor/partire	33 bout de demar/arr d'urg
34 Batterie 12V 8Ah	34 battery 12V 8Ah	34 batteria 12V 8Ah	34 batterie 12V 8Ah
35 EPC	35 EPC	35 EPC	35 EPC
36 Lüftermotor	36 fan motor	36 ventilatore	36 ventilateur
37 Startrelais	37 starter relay	37 rele d'avviamento	37 relaise de demarreur
38 Startermotor	38 starter engine	38 mot d'avviamento elettr	38 demarreur electrique
39 Parallelverbinder	39 parallel connector	39 parallelo composto	39 parallele connecteur
40 Kupplungsschalter	40 clutch switch	40 interruttore frizione	40 contact de embrayage
41 ThermoSchalter	41 temperature switch	41 int temperatura	41 contact de temperature
42 Starterhilfsrelais	42 starter auxil relay	42 rele avviam ausiliario	42 relaise auxil demarrage
43 Vergaserschalter	43 carburetor switch	43 interruttore carburatore	43 contact de carburateur
44 Magnetventil	44 magnetic valve	44 valvola elettromagnetica	44 electrovanne
45 Kondensator	45 capacitor	45 condensatore	45 condensateur
46 Impulsgeber	46 pulser coil	46 trasmettitore d'impulsi	46 capteur
47 12-pol Stecker	47 multip cont plug (12)	47 connettore a 12 poli	47 connect multiple (12)
48 Diode	48 diode	48 diodo	48 diode
49 Kontaktstift 3 Gang	49 gear switch 3rd gear	49 3 secondo marcia	49 cont d boîte d vites (3)
50 Kontaktstift 2 Gang	48 gear switch 2th gear	50 2 secondo marcia	50 cont d bolte d vites (2)

Spanisch	Deutsch	Englisch	Italienisch	Französisch
1 fero	1 fero	18 interruptor temperatura	35 EPC	
2 luz de posicion	2 luz de posicion	19 interruptor luz de frendo tras	36 ventilador electrica	
3 interm izquierdo delantero	3 interm izquierdo delantero	20 bujia	37 rele de arranque	
4 intermitente derecho delantero	4 intermitente derecho delantero	21 bobina de encendido	38 motor de arranque	
5 control temperatura	5 control temperatura	22 generador	39 conector paralelo	
6 indicador punto muerto	6 indicador punto muerto	23 regulador de tension	40 interruptor de embraque	
7 luz tacometro	7 luz tacometro	24 intermitente izquierdo trasero	41 interruptor temperatura	
8 lampara aviso luces largas	8 lampara aviso luces largas	25 intermitente derecho trasero	42 rele del arranque	
9 lampara aviso intermitentes	9 lampara aviso intermitentes	26 luz de freno trasero	43 interruptor de carburador	
10 llave de contacto	10 llave de contacto	27 unidad cdi	44 valvola magnetica	
11 fusible 10A	11 fusible 10A	28 conecdor multiple (2)	45 condensador	
12 interruptor combinado	12 interruptor combinado	29 conector multiple (4)	46 generado de impulsos	
13 conector a masa	13 conector a masa	30 conector multiple (6)	47 conector multiple (12)	
14 conjunto del intermitente	14 conjunto del intermitente	31 conector multiple (9)	48 diodo	
15 claxon	15 claxon	32 fusible principal 20A	49 interruptor de cambio (3)	
16 interruptor	16 interruptor	33 boton de arranque par de urg	50 interruptor de cambio (2)	
17 interruptor punto muerto	17 interruptor punto muerto	34 bateria 12V 8 Ah		

Deutsch	Englisch	Italienisch	Französisch	Spanisch
bl blau	bl blue	bl blu	bl bleu	bl azul
br braun	br brown	br marrone	br brun	br marron
ge gelb	ge yellow	ge giallo	ge jaune	ge amarillo
gr grau	gr grey	gr grigio	gr gris	gr gris
g grün	g green	g verde	g vert	g verde
o orange	o orange	o arancione	o orange	o naranja
r rot	r red	r rosso	r rouge	r rojo
ra rosa	ra pink	ra rosa	ra rose	ra rosado
s schwarz	s black	s nero	s noir	s negro
v violett	v violet	v violetto	v violet	v violeta
w weiß	w white	w bianco	w blanc	w blanco

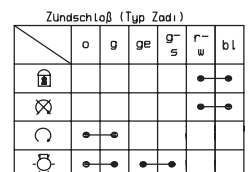
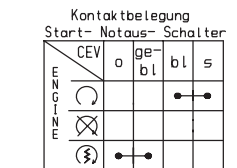
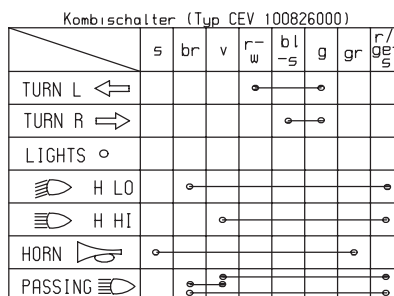



Deutsch	Englisch	Italienisch	Französisch
1 Scheinwerfer	1 headlight	1 fero	1 phare
2 Standlicht	2 parking light	2 luce di posizione	2 feu de position
3 Blinker li vo	3 blinker left front	3 lampegg ant sn	3 clignoteur av gauche
4 Blinker re vo	4 blinker right front	4 lampegg ant dx	4 clignoteur av droit
5 Temperaturkontrolle	5 temperature control	5 controllo temperatura	5 témoin de temperature
6 Leerlaufanzeige	6 neutral	6 indicat marcia folle	6 ind de point mort
7 Tachobeleuchtung	7 tachometer light	7 luce di tachimetro	7 éclair comp vitesse
8 Fernlichtkontrolle	8 high beam control	8 spia abbagliante	8 témoin de feu route
9 Blinkerkontrolle	9 blink control	9 spia lampeggiatori	9 témoin de clignoteur
10 Zündschloß	10 ignition switch	10 int accensione	10 contact d'allum
11 Sicherung 10A	11 fuse 10A	11 fusibile 10A	11 fusible 10A
12 zum Kombischalter	12 to combinat switch	12 multicomando	12 vers commutateur
13 Masseanschluß	13 ground connection	13 collegam a massa	13 masse
14 Blinkgeber	14 blink signal system	14 trasmett di lampeg	14 centrale clignot
15 Horn	15 horn	15 clacson	15 klaxon
16 Bremslichtsch vo	16 stoplight switch f	16 int luce arresto ant	16 cont av de stop
17 Leerlaufschalter (N)	17 neutral switch (N)	17 interr luce folle (N)	17 contact pt mort (N)
18 Thermostalter	18 temperature switch	18 int temperatura	18 contact de temperature
19 Bremslichtsch hi	19 stoplight switch r	19 int luce arresto post	19 contact arr de stop
20 Zündkerze	20 spark plug	20 candela	20 bougie
21 Zündspule	21 ignition coil	21 bobina d'accens	21 bobine d'allumage
22 Generator	22 generator	22 dinamo	22 generateur
23 Regelgleichrichter	23 regulator-rectifier	23 regolatore di tens	23 regulat redresseur
24 Blinker li hi	24 blinker left rear	24 lampegg post sn	24 clign arr gauche
25 Blinker re hi	25 blinker right rear	25 lampegg post dx	25 clign arr droit
26 Brems-Schlußlicht	26 rear-stoplight	26 fanal post di freno	26 feu arr et de stop
27 CDI-Einheit	27 CDI-unit	27 CDI-seatola	27 boitier CDI
28 2-pol Stecker	28 multip cont plug (2)	28 connettore a 2 poli	28 connect multiple (2)
29 4-pol Stecker	29 multip cont plug (4)	29 connettore a 4 poli	29 connect multiple (4)
30 6-pol Stecker	30 multip cont plug (6)	30 connettore a 6 poli	30 connect multiple (6)
31 9-pol Stecker	31 multip cont plug (9)	31 connettore a 9 poli	31 connect multiple (9)
32 Hauptsicherung 20A	32 mainfuse 20A	32 fusibile principale 20A	32 fusible principal 20A
33 Starttast Notaussch	33 run-off/start switch	33 disinseritor/partire	33 bout de demar/arr d'urg
34 Batterie 12V 8Ah	34 battery 12V 8Ah	34 batteria 12V 8Ah	34 batterie 12V 8Ah
36 Lüftermotor	36 fan motor	36 ventilatore	36 ventilateur
37 Startrelais	37 starter relay	37 rele d'avviamento	37 relaise de demarreur
38 Startermotor	38 starter engine	38 mot d'avviamento elettr	38 demarreur electrique
39 Parallelverbinder	39 parallel connector	39 parallelo composto	39 parallele connecteur
40 Kupplungsschalter	40 clutch switch	40 interruttore frizione	40 contact de embrayage
41 Thermostalter	41 temperature switch	41 int temperatura	41 contact de temperature
42 Starterhilfsrelais	42 startar auxil relay	42 rele avviam ausiliario	42 relaise auxil demarrage
45 Kondensator	45 capacitor	45 condensatore	45 condensateur
46 Impulsgeber	46 pulser coil	46 trasmettitore d'impulsi	46 capteur
47 12-pol Stecker	47 multip cont plug (12)	47 connettore a 12 poli	47 connect multiple (12)
48 Diode	48 diode	48 diodo	48 diode
49 Kontaktstift 3 Gang	49 gear switch 3rd gear	49 3 secondo marcia	49 cont d boîte d vites (3)
50 Kontaktstift 2 Gang	48 gear switch 2th gear	50 2 secondo marcia	50 cont d bolte d vites (2)

Spanisch	Englisch	Italienisch	Französisch
1 fero	18 interruptor temperatura	36 ventilador electrica	
2 luz de posicion	19 interruptor luz de frendo tras	37 rele de arranque	
3 interm izquierdo delantero	20 bujia	38 motor de arranque	
4 intermitente derecho delantero	21 bobina de encendido	39 conector paralelo	
5 control temperatura	22 generador	40 interruptor de embrague	
6 indicador punto muerto	23 regulador de tension	41 interruptor temperatura	
7 luz tacometro	24 intermitente izquierdo trasero	42 rele del arranque	
8 lampara aviso luces largas	25 intermitente derecho trasero	45 condensador	
9 lampara aviso intermitentes	26 luz de freno trasero	46 generado de impulsos	
10 llave de contacto	27 unidad cdi	47 conector multiple (12)	
11 fusible 10A	28 conecdor multiple (2)	48 diodo	
12 interruptor combinado	29 conector multiple (4)	49 interruptor de cambio (3)	
13 conector a masa	30 conector multiple (6)	50 interruptor de cambio (2)	
14 conjunto del intermitente	31 conector multiple (9)		
15 claxon	32 fusible principal 20A		
16 interruptor	33 boton de arranque par de urg		
17 interruptor punto muerto	34 bateria 12V 8 Ah		

Deutsch	Englisch	Italienisch	Französisch	Spanisch
bl blau	bl blue	bl blu	bl bleu	bl azul
br braun	br brown	br marrone	br brun	br marron
ge gelb	ge yellow	ge giallo	ge jaune	ge amarillo
gr grau	gr grey	gr grigio	gr gris	gr gris
g grün	g green	g verde	g vert	g verde
o orange	o orange	o arancione	o orange	o naranja
r rot	r red	r rosso	r rouge	r rojo
ra rosa	ra pink	ra rosa	ra rose	ra rosado
s schwarz	s black	s nero	s noir	s negro
v violett	v violet	v violetto	v violet	v violeta
w weiß	w white	w bianco	w blanc	w blanco

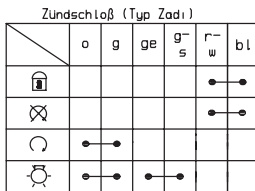
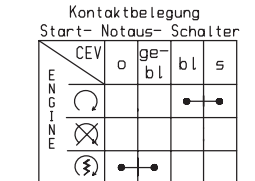
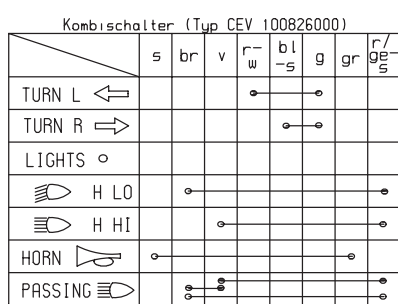

SERVICE

Modell 400 LC4-E '98

Kabelstrangnummer  
vorne 584 11 175 200  
hinten 584 11 176 100

Land  
DIV LANDEK

Datum, Name  
16 04 98 KE

Kabelstrangbez  
vo  
hi

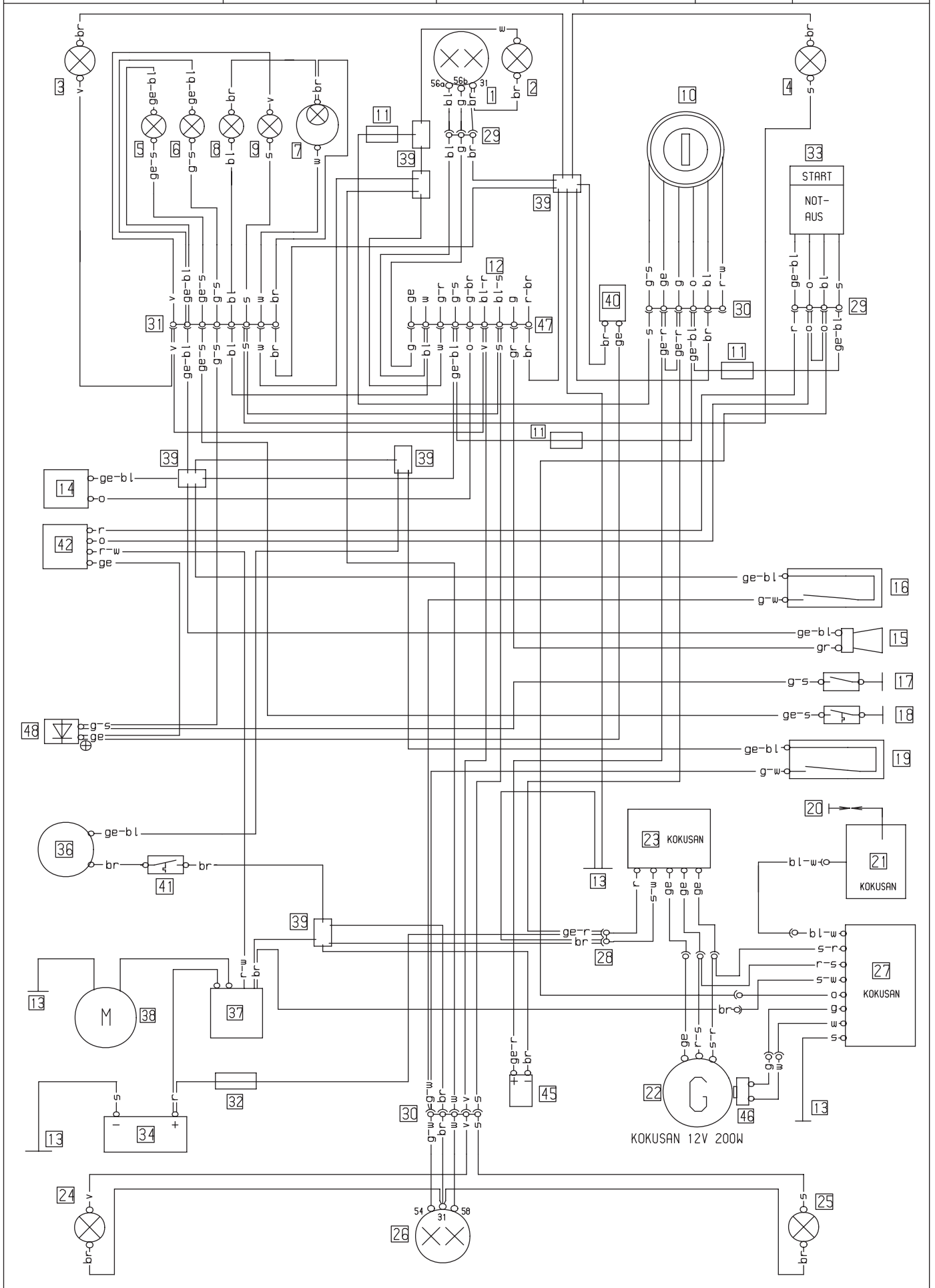

Deutsch	Englisch	Italienisch	Französisch
1 Scheinwerfer	1 headlight	1 fano	1 phare
2 Standlicht	2 parking light	2 luce di posizione	2 feu de position
3 Blinker li vo	3 blinker left front	3 lampegg ant sn	3 clignoteur av gauche
4 Blinker re vo	4 blinker right front	4 lampegg ant dx	4 clignoteur av droit
5 Temperaturkontrolle	5 temperature control	5 controllo temperatura	5 témoin de temperature
6 Leerlaufanzeige	6 neutral	6 indicat marcia folle	6 ind de point mort
7 Tachobeleuchtung	7 tachometer light	7 luce di tachimetro	7 éclair comp vitesse
8 Fernlichtkontrolle	8 high beam control	8 spia abbagliante	8 témoin de feu route
9 Blinkerkontrolle	9 blink control	9 spia lampeggiatori	9 témoin de clignoteur
10 Zündschloß	10 ignition switch	10 int accensione	10 contact d'allum
11 Sicherung 10A	11 fuse 10A	11 fusibile 10A	11 fusible 10A
12 zum Kombischalter	12 to combinat switch	12 multicomando	12 vers commutateur
13 Masseanschluß	13 ground connection	13 collegam a massa	13 masse
14 Blinkgeber	14 blink signal system	14 trasmett di lampeg	14 centrale clignot
15 Horn	15 horn	15 clacson	15 klaxon
16 Bremslichtsch vo	16 stoplight switch f	16 int luce arresto ant	16 cont av de stop
17 Leerlaufschalter (N)	17 neutral switch (N)	17 interr luce folle (N)	17 contact pt mort (N)
18 Thermostochalter	18 temperature switch	18 int temperatura	18 contact de temperature
19 Bremslichtsch hi	19 stoplight switch r	19 int luce arresto post	19 contact arr de stop
20 Zündkerze	20 spark plug	20 candela	20 bougie
21 Zündspule	21 ignition coil	21 bobina d'accens	21 bobine d'allumage
22 Generator	22 generator	22 dinamo	22 generateur
23 Regelgleichrichter	23 regulator-rectifier	23 regolatore di tens	23 regulat redresseur
24 Blinker li hi	24 blinker left rear	24 lampegg post sn	24 clign arr gauche
25 Blinker re hi	25 blinker right rear	25 lampegg post dx	25 clign arr droit
26 Brems-Schlußlicht	26 rear-stoplight	26 fanal post di freno	26 feu arr et de stop
27 CDI-Einheit	27 CDI-unit	27 CDI-seatola	27 boitier CDI
28 2-pol Stecker	28 multip cont plug (2)	28 connettore a 2 poli	28 connect multiple (2)
29 4-pol Stecker	29 multip cont plug (4)	29 connettore a 4 poli	29 connect multiple (4)
30 6-pol Stecker	30 multip cont plug (6)	30 connettore a 6 poli	30 connect multiple (6)
31 9-pol Stecker	31 multip cont plug (9)	31 connettore a 9 poli	31 connect multiple (9)
32 Hauptsicherung 20A	32 mainfuse 20A	32 fusibile principale 20A	32 fusible principal 20A
33 Starttast Notaus	33 run-off/start switch	33 disinseritor/partire	33 bout de demar/arr d'urg
34 Batterie 12V 8Ah	34 battery 12V 8Ah	34 batteria 12V 8Ah	34 batterie 12V 8Ah
36 Lüftermotor	36 fan motor	36 ventilatore	36 ventilateur
37 Startrelais	37 starter relay	37 rele d'avviamento	37 relaise de demarreur
38 Startermotor	38 starter engine	38 mot d'avviamento elettr	38 demarreur electrique
39 Parallelverbinder	39 parallel connector	39 parallelo composto	39 parallele connecteur
40 Kupplungsschalter	40 clutch switch	40 interruttore frizione	40 contact de embrayage
41 Thermostochalter	41 temperature switch	41 int temperatura	41 contact de temperature
42 Starterhilfsrelais	42 startor auxil relay	42 rele avviam ausiliario	42 relaise auxil demarrage
45 Kondensator	45 capacitor	45 condensatore	45 condensateur
46 Impulsgeber	46 pulser coil	46 trasmettitore d'impulsi	46 capteur
47 12-pol Stecker	47 multip cont plug (12)	47 connettore a 12 poli	47 connect multiple (12)
48 Diode	48 diode	48 diodo	48 diode

Spanisch	18 interruptor temperatura	36 ventilador electrica
1 fano	18 interruptor temperatura	36 ventilador electrica
2 luz de posicion	19 interruptor luz de frendo tras	37 rele de arranque
3 interm izquierdo delantero	20 bujia	38 motor de arranque
4 intermitente derecho delantero	21 bobina de encendido	39 conector paralelo
5 control temperatura	22 generador	40 interruptor de embraque
6 indicador punto muerto	23 regulador de tension	41 interruptor temperatura
7 luz tacometro	24 intermitente izquierdo trasero	42 rele del arranque
8 lampara aviso luces largas	25 intermitente derecho trasero	45 condensador
9 lampara aviso intermitentes	26 luz de freno trasero	46 generador de impulsos
10 llave de contacto	27 unidad cdi	47 conector multiple (12)
11 fusible 10A	28 conecdor multiple (2)	48 diodo
12 interruptor combinado	29 conector multiple (4)	
13 conector a masa	30 conector multiple (6)	
14 conjunto del intermitente	31 conector multiple (9)	
15 claxon	32 fusible principal 20A	
16 interruptor	33 boton de arranque par de urg	
17 interruptor punto muerto	34 bateria 12V 8 Ah	

Deutsch	Englisch	Italienisch	Französisch	Spanisch
bl blau	bl blue	bl blu	bl bleu	bl azul
br braun	br brown	br marrone	br brun	br marron
ge gelb	ge yellow	ge giallo	ge jaune	ge amarillo
gr grau	gr grey	gr grigio	gr gris	gr gris
g grün	g green	g verde	g vert	g verde
o orange	o orange	o arancione	o orange	o naranja
r rot	r red	r rosso	r rouge	r rojo
ra rosa	ra pink	ra rosa	ra rose	ra rosado
s schwarz	s black	s nero	s noir	s negro
v violett	v violet	v violetto	v violet	v violeta
w weiß	w white	w bianco	w blanc	w blanco

